

Aluform

Applications

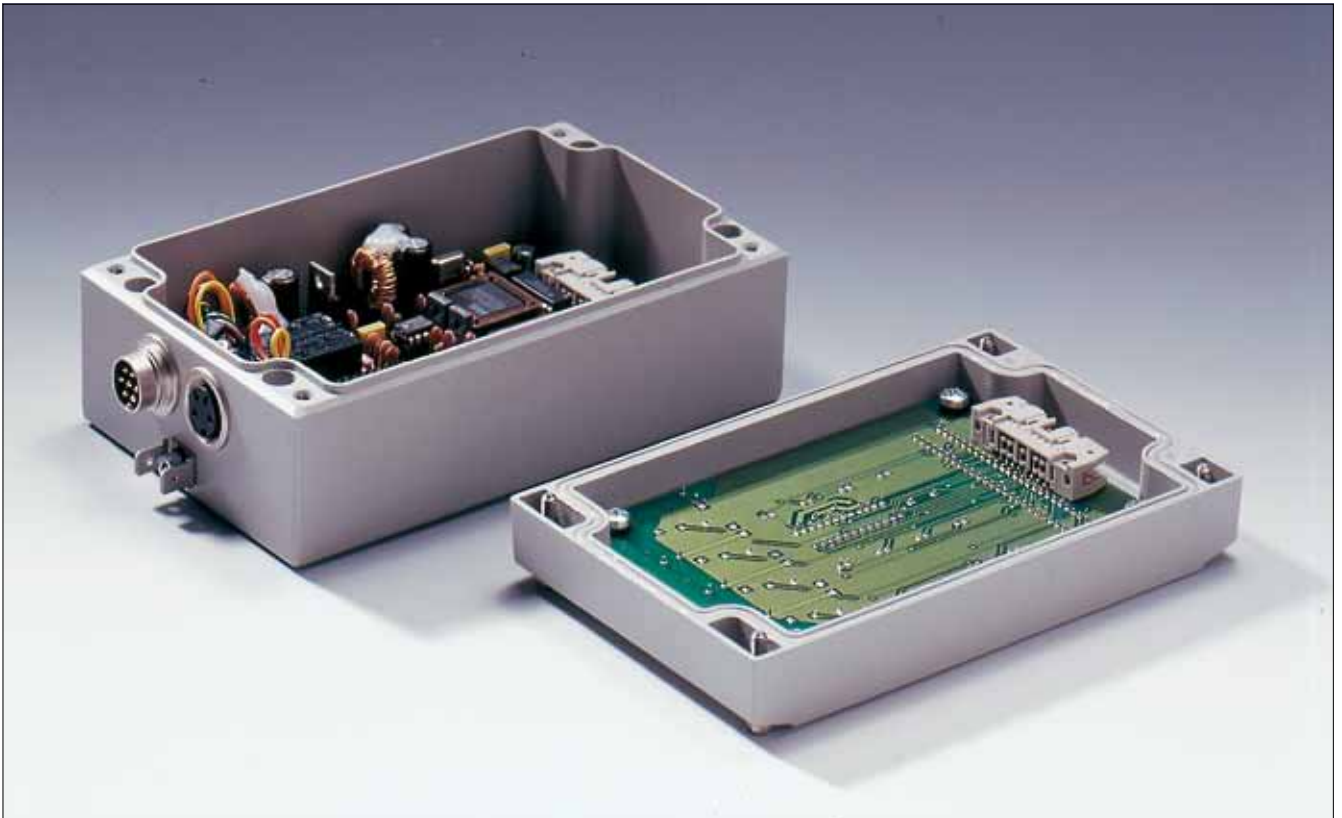



- Aluminium diecast enclosure for MCR and automation technology
- Prepared for acceptance for front membranes and keypads
- Rectangular dome sequence in lid and base

Technical Data

Material:

DIN EN 1706 EN AC-AISI 12 (Fe)

Painting:

powder coating

Colour:

RAL 7038, agate grey

special colour on request

Ingress protection:

IP 66 to EN 60529

higher protection on request

Impact resistance:

7 Joule to EN 60079-0

Temperature range:

PU (polyurethane) seal (std.): -40°C to +90°C

CR (chloroprene) seal: -40°C to +100°C

VMQ (silicone) seal (optional): -60°C to +130°C

Included in delivery

Aluminium diecast enclosure consisting of lid, seal incl. captive +/- stainless steel screws, base with 4 earthing screws

Aluform

Product range

Order No.	B x L x H (mm)	Mounting plate	DIN rail TS 15	DIN rail TS 35	External mounting brackets (pair)
04.08 08 08	80 x 80 x 81	10.01 10 60	10.06 10 03		04.00 00 80
04.08 12 05	80 x 120 x 51	10.01 10 61			04.00 00 80
04.08 12 08	80 x 120 x 81	10.01 10 61	10.06 10 50		04.00 00 80
04.10 10 06	100 x 100 x 61	10.01 10 31	10.06 10 07	10.06 14 71	04.00 01 00
04.10 16 06	100 x 160 x 61	10.01 10 32	10.06 10 08	10.06 14 72	04.00 01 00
04.10 20 06	100 x 200 x 61	10.01 10 33	10.06 10 09	10.06 14 73	04.00 01 00
04.12 12 08	120 x 120 x 81	10.01 10 62	10.06 10 50	10.06 14 83	04.00 01 20
04.12 16 08	120 x 160 x 81	10.01 10 63	10.06 10 08	10.06 14 72	04.00 01 20
04.14 14 07	140 x 140 x 71	10.01 10 34	10.06 10 44	10.06 14 74	04.00 01 40
04.14 18 07	140 x 180 x 71	10.01 10 35	10.06 10 05	10.06 14 75	04.00 01 40
04.14 22 07	140 x 220 x 72	10.01 10 36	10.06 10 46	10.06 14 76	04.00 01 40
04.15 18 08	150 x 180 x 81	10.01 10 70	on request	on request	
04.16 16 08	160 x 160 x 81	10.01 10 64	10.06 10 08	10.06 14 72	04.00 01 60
04.16 24 08	160 x 240 x 81	10.01 10 65	10.06 10 51	10.06 14 84	04.00 01 60
04.20 20 07	200 x 200 x 72	10.01 10 37	10.06 10 09	10.06 14 73	04.00 02 00
04.20 28 07	200 x 280 x 72	10.01 10 59	10.06 10 48	10.06 14 81	04.00 02 00
04.28 28 11	280 x 280 x 111	10.01 10 71	10.06 10 48	10.06 14 81	

Accessories

Type	DIN rails for terminals		Mounting plate 1)	External mounting brackets pair	External aluminium hinges pair 3), 4)	EMC screening	SWB/SBG/SBGL Corrosion protection	Allen lid screws 2)	Silicone lid seal up to +130°C	Sealable lid screws in steel	Lid safety strip
	TS 15	TS 35									
04.08 08 08	•		•	•	•	•	•	•	•	•	•
04.08 12 05			•	•	•	•	•	•	•	•	•
04.08 12 08	•		•	•	•	•	•	•	•	•	•
04.10 10 06	•	•	•	•	•	•	•	•	•	•	•
04.10 16 06	•	•	•	•	•	•	•	•	•	•	•
04.10 20 06	•	•	•	•	•	•	•	•	•	•	•
04.12 12 08	•	•	•	•	•	•	•	•	•	•	•
04.12 16 08	•	•	•	•	•	•	•	•	•	•	•
04.14 14 07	•	•	•	•	•	•	•	•	•	•	•
04.14 18 07	•	•	•	•	•	•	•	•	•	•	•
04.14 22 07	•	•	•	•	•	•	•	•	•	•	•
04.15 18 08	•	•	•		•	•	•	•	•	•	•
04.16 16 08	•	•	•	•	•	•	•	•	•	•	•
04.16 24 08	•	•	•	•	•	•	•	•	•	•	•
04.20 20 07	•	•	•	•	•	•	•	•	•	•	•
04.20 28 07	•	•	•	•	•	•	•	•	•	•	•
04.28 28 11	•	•	•		•	•	•	•	•	•	•

1) Laminated paper

2) Stainless steel

3) Diecast aluminium

4) Please quote the installation side A-D when ordering

Terminal mounting

Make	Phoenix																Earth connection as required		
DIN rail TS 15	X	X	X																
DIN rail TS 35				X	X	X	X	X	X	X	X								
Voltage (V)	250	500	500	500	800	800	800	800	800	800	1000								
Current (A)	24	24	32	17,5	24	24	32	41	57	76	150								
Nom. cross section (mm ²)	2,5	2,5	4	1,5	2,5	2,5	4	6	10	16	35								
Terminal width (mm)	5,2	5,2	6,2	4,2	5,2	5,2	6,2	8,2	10,2	12,2	15,2								
Terminal type																			
Type	MBK 2,5 E	MBK 3 / E-Z	MBK 5 / E-Z	UK 1,5 N	UK 2,5 N	UK 3 N	UK 5 N	UK 6 N	UK 10 N	UK 16 N	UK 35								
04.08 08 08	7	7	5	6	5	5	4	3	2	2									
04.08 12 05																			
04.08 12 08	14	14	12	16	13	13	11	8	6	5									
04.10 10 06	11	11	9	11															
04.10 16 06	22	22	18	25															
04.10 20 06	30	30	25	35															
04.12 12 08	14	14	12	16	13	13	11	8	6	5									
04.12 16 08	22	22	18	25	20	20	17	13	10	8									
04.14 14 07	18	18	15	21	17	17	14	10	8										
04.14 18 07	26	26	22	30	24	24	20	15	12										
04.14 22 07	34	34	28	40	32	32	27	20	16										
04.15 18 08	26	26	22	30	24	24	20	15	12	7									
04.16 16 08	34	34	18	25	20	20	17	13	10	8									
04.16 24 08	37	37	31	45	36	36	30	23	18	15									
04.20 20 07	30	30	25	35	28	28	23	18	14										
04.20 28 07	45	45	38	54	44	44	36	27	22										
04.28 28 11	45	45	38	54	44	44	36	27	22	18	15								

Make	Weidmüller																Earth connection as required		
DIN rail TS 15	X	X	X	X															
DIN rail TS 35					X	X	X	X	X	X	X								
Voltage (V)	250	250	400	400	800	500	800	800	1000	690	690								
Current (A)	17,5	24	32	17,5	24	24	32	41	57	66	109								
Nom. cross section (mm ²)	1,5	2,5	4	1,5	2,5	2,5	4	6	10	16	35								
Terminal width (mm)	5,1	5,1	6,1	3,5	5,1	5,1	6,1	7,9	9,9	11,9	16								
Terminal type																			
Type	AKZ 1,5	AKZ 2,5	AKZ 4	WDU 1,5 / R 3,5	WDU 2,5	WDU 2,5 N	WDU 4	WDU 6	WDU 10	WDU 16	WDU 35								
04.08 08 08	5	5	4	8	6	6	5	4	3										
04.08 12 05																			
04.08 12 08	13	13	11	19	14	14	11	9	7										
04.10 10 06	9	9	7	13		10													
04.10 16 06	20	20	17	31		21													
04.10 20 06	28	28	24	42		29													
04.12 12 08	13	13	11	19	14	14	11	9	7										
04.12 16 08	20	20	17	31	21	21	18	14	11										
04.14 14 07	16	16	14	25	18	18	15	11											
04.14 18 07	24	24	20	36	25	25	21	16											
04.14 22 07	32	32	27	48	33	33	28	21											
04.15 18 08	24	24	20	36	25	25	21	16	9	9	9								
04.16 16 08	20	20	17	31	21	21	18	14	11										
04.16 24 08	36	36	30	53	37	37	31	24	19										
04.20 20 07	28	28	24	42	29	29	24	19											
04.20 28 07	43	43	37	65	45	45	38	29											
04.28 28 11	43	43	38	54	44	44	36	27	22	19	15								

Aluform

Accessories



External mounting brackets (set = 2 pcs.)
for mounting without opening the lid

Order No.	A	B	for type	Order No.	A	B	for type
04.00 00 80	65	92	04.08 08 08	04.00 01 40	125	152	04.14 14 07
04.00 00 80	65	132	04.08 12 08	04.00 01 40	125	192	04.14 18 07
04.00 01 00	85	112	04.10 10 06	04.00 01 40	125	232	04.14 22 07
04.00 01 00	85	172	04.10 16 06	04.00 01 60	145	172	04.16 16 08
04.00 01 00	85	212	04.10 20 06	04.00 01 60	145	252	04.16 24 08
04.00 01 20	105	132	04.12 12 08	04.00 02 00	185	212	04.20 20 07
04.00 01 20	105	172	04.12 16 08	04.00 02 00	185	292	04.20 28 07

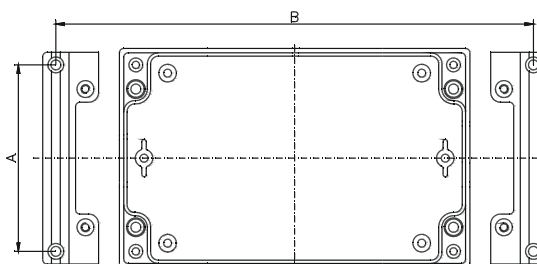

Panel holder
to convert the Aluform enclosure into a multi-functional control terminal
wall or table mounting
sheet steel material; powder coated, RAL 7030, stone grey

Order No.	width	for type
04.30 00 09	98 mm	04.10 10 06 04.10 16 06 04.10 20 06
04.30 00 14	138 mm	04.14 14 07 04.14 18 07 04.14 22 07



External hinge (set = 2 pcs)

Order No. **04.00 00 10**

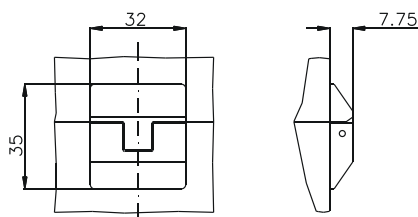

Accessories



Lid safety strip
set = 2 pcs.

Note: for fastening base has to be manufactured

Order No. **04.00 00 20**

Type: **04.08 08 08**

External dimensions: **80 x 80 x 81 mm**

Weight: **580 g**

DIN rail length in mm	max. fitting length in mm	Mounting plate (thickness in mm)	External mounting brackets	External hinge* set	EMC version	SWB / SBG / SBGL corrosion protection	Allen lid screws	Silicone lid seal	Sealable lid screws in steel	Lid safety strip
TS 15										
63	50	2	•	•	•	•	•	•	•	•

Maximum number of cable glands to DIN 50262*

M	Corner dim.	Side		PG	Corner dim.	Side	
		A/B	C/D			A/B	C/D
12	17,25	8	3	7	17,25	8	3
16	25,30	4	2	9	21,85	5	2
20	27,60	3	1	11	25,30	4	2
25	37,95	1	1	13,5	27,60	3	1
32	48,30	1		16	31,05	2	1
40	60,95			21	37,95	1	
50	69,00			29	48,30	1	
63	74,75			36	60,95		
				42	69,00		
				48	74,75		

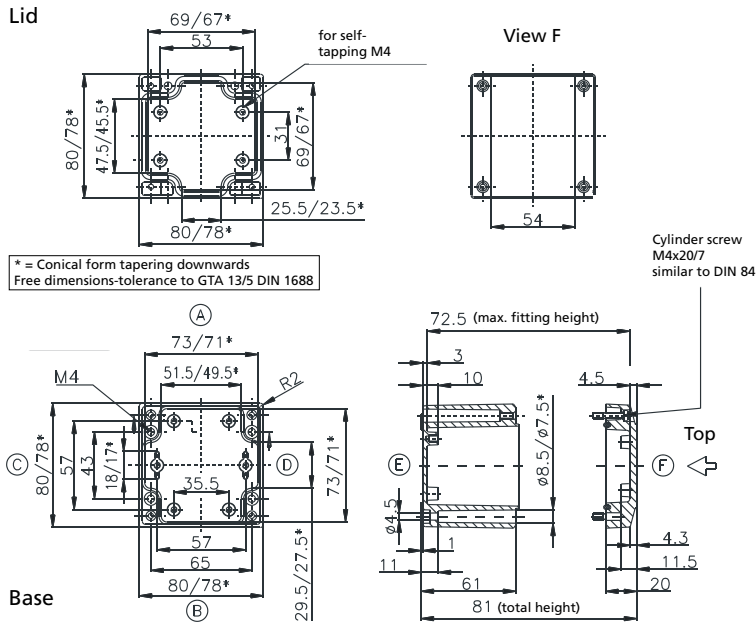

Type: **04.08 12 05**

External dimensions: **80 x 120 x 51 mm**

Weight: **436 g**

DIN rail length in mm	max. fitting length in mm	Mounting plate (thickness in mm)	External mounting brackets	External hinge* set	EMC version	SWB / SBG / SBGL corrosion protection	Allen lid screws	Silicone lid seal	Sealable lid screws in steel	Lid safety strip
			•	•	•	•	•	•	•	•

Max. Bestückungsmöglichkeit für Kabelverschraubungen nach DIN 50262*

M	Corner dim.	Side		PG	Corner dim.	Side	
		A/B	C/D			A/B	C/D
12	17,25	6	1	7	17,25	6	1
16	25,30	3	1	9	21,85	4	1
20	27,60	3		11	25,30	3	
25	37,95			13,5	27,60	3	
32	48,30			16	31,05		
40	60,95			21	37,95		
50	69,00			29	48,30		
63	74,75			36	60,95		
				42	69,00		
				48	74,75		

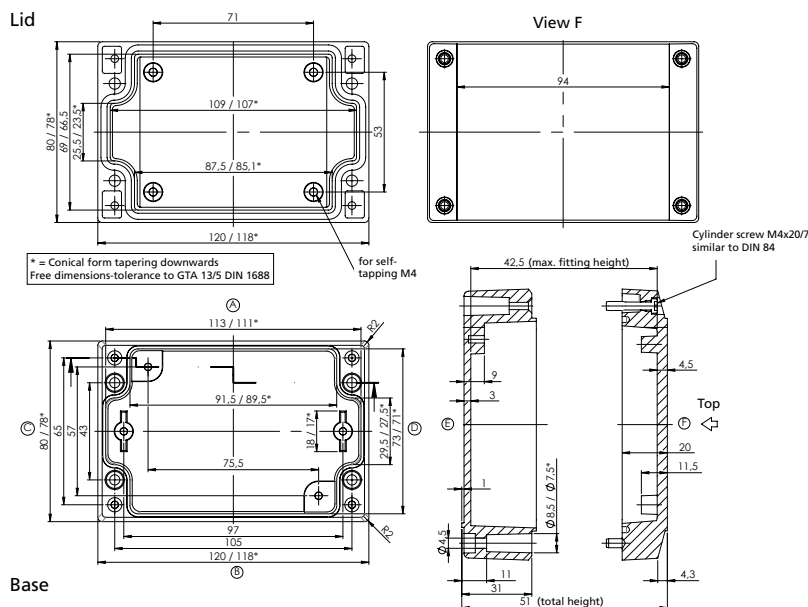

* Please quote mounting side

Type: **04.08 12 08**

External dimensions: **80 x 120 x 81 mm**

Weight: **650 g**

DIN rail length in mm	max. fitting length in mm	Mounting plate (thickness in mm)	External mounting brackets	External hinge* set	EMC version	SWB / SBGL corrosion protection	Allen lid screws	Silicone lid seal	Sealable lid screws in steel	Lid safety strip
TS 15										
107	90	2	•	•	•	•	•	•	•	•

Maximum number of cable glands to DIN 50262*

M	Corner dim.	Side		PG	Corner dim.	Side	
		A/B	C/D			A/B	C/D
12	17,25	15	3	7	17,25	15	3
16	25,30	6	2	9	21,85	8	2
20	27,60	5	1	11	25,30	6	2
25	37,95	2	1	13,5	27,60	5	1
32	48,30	2		16	31,05	3	1
40	60,95			21	37,95	2	
50	69,00			29	48,30	2	
63	74,75			36	60,95		
				42	69,00		
				48	74,75		

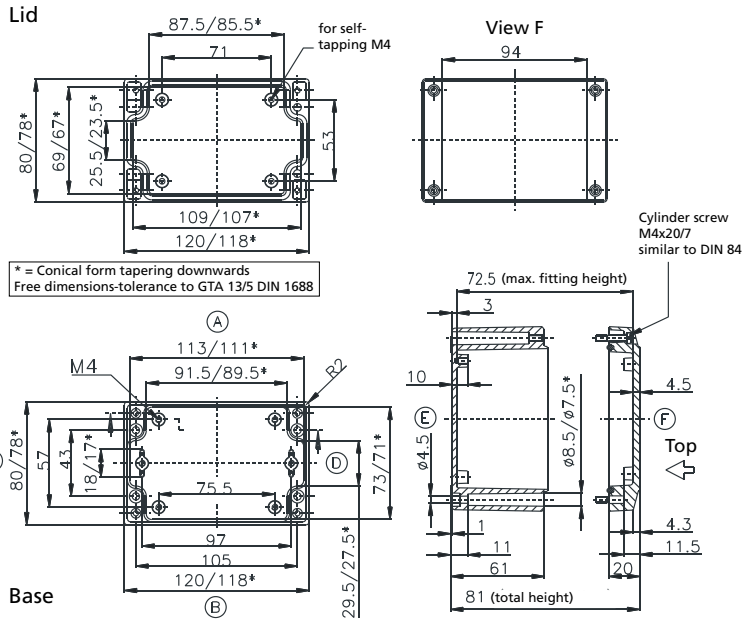

Type: **04.10 10 06**

External dimensions: **100 x 100 x 61 mm**

Weight: **650 g**

DIN rail length in mm	max. fitting length in mm	Mounting plate (thickness in mm)	External mounting brackets	External hinge* set	EMC version	SWB / SBGL corrosion protection	Allen lid screws	Silicone lid seal	Sealable lid screws in steel	Lid safety strip
TS 15/TS 35										
87,5	70	2	•	•	•	•	•	•	•	•

Maximum number of cable glands to DIN 50262*

M	Corner dim.	Side		PG	Corner dim.	Side	
		A/B	C/D			A/B	C/D
12	17,25	6	4	7	17,25	5	4
16	25,30	3	2	9	21,85	3	2
20	27,60	2	2	11	25,30	3	2
25	37,95			13,5	27,60	2	2
32	48,30			16	31,05	2	1
40	60,95			21	37,95		
50	69,00			29	48,30		
63	74,75			36	60,95		
				42	69,00		
				48	74,75		

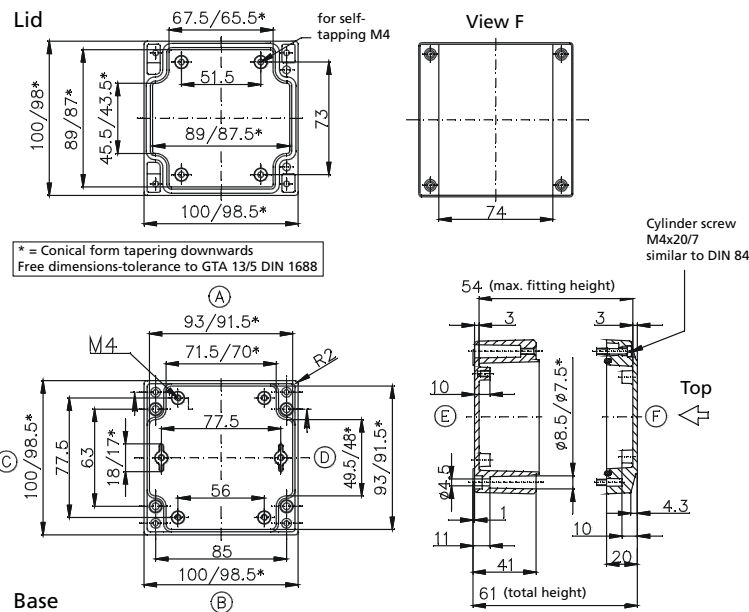

* Please quote mounting side

Type: **04.10 16 06**

External dimensions: **100 x 160 x 61 mm**

Weight: **820 g**

DIN rail length in mm	max. fitting length in mm	Mounting plate (thickness in mm)	External mounting brackets	External hinge* set	EMC version	SWB / SBGL corrosion protection	Allen lid screws	Silicone lid seal	Sealable lid screws in steel	Lid safety strip
TS 15/TS 35										
148	130	2	•	•	•	•	•	•	•	•

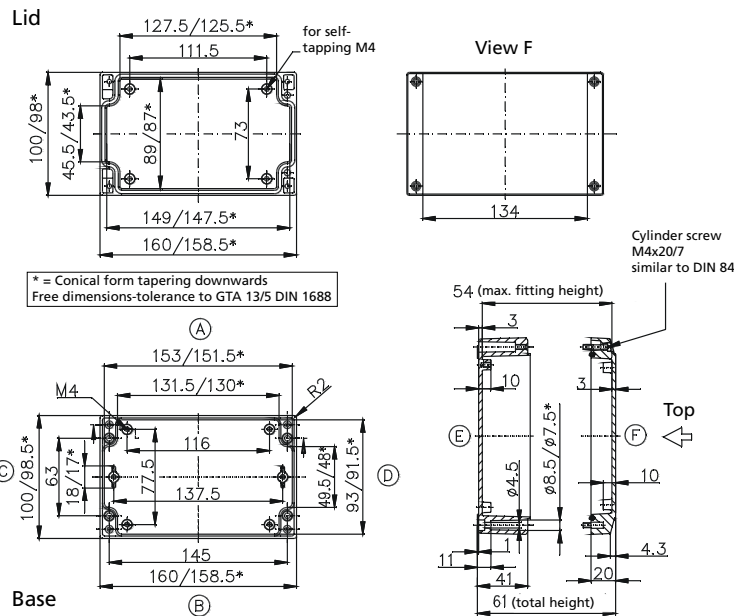
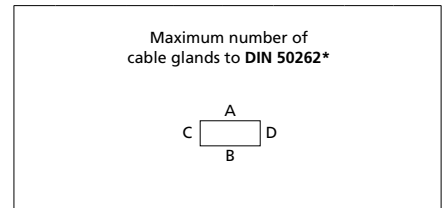

M	Corner dim.	Side		PG	Corner dim.	Side	
		A/B	C/D			A/B	C/D
12	17,25	11	4	7	17,25	11	4
16	25,30	5	2	9	21,85	6	2
20	27,60	4	2	11	25,30	5	2
25	37,95			13,5	27,60	4	2
32	48,30			16	31,05	4	1
40	60,95			21	37,95		
50	69,00			29	48,30		
63	74,75			36	60,95		
				42	69,00		
				48	74,75		

Type: **04.10 20 06**

External dimensions: **100 x 200 x 61 mm**

Weight: **840 g**

DIN rail length in mm	max. fitting length in mm	Mounting plate (thickness in mm)	External mounting brackets	External hinge* set	EMC version	SWB / SBGL corrosion protection	Allen lid screws	Silicone lid seal	Sealable lid screws in steel	Lid safety strip
TS 15/TS 35										
188	170	2	•	•	•	•	•	•	•	•

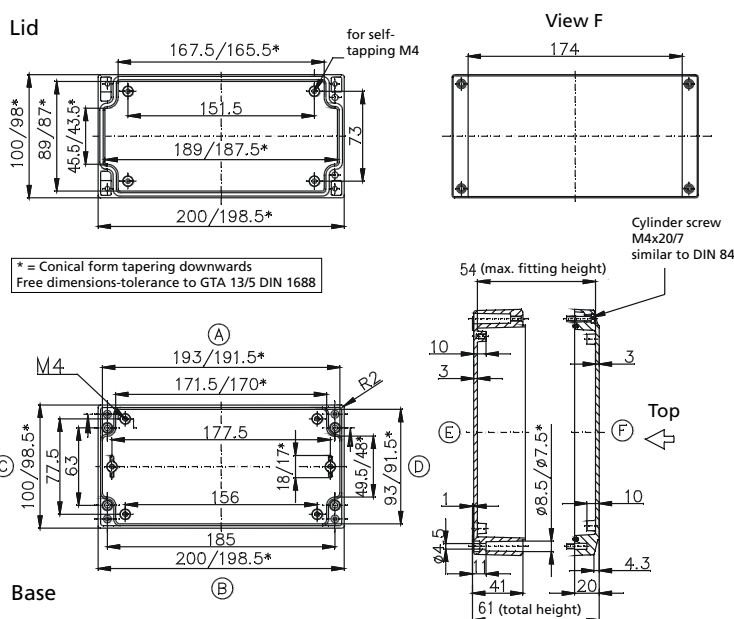
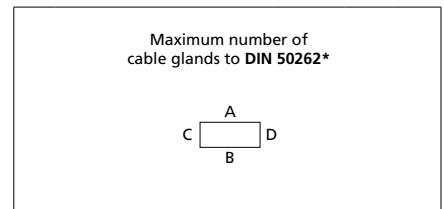

M	Corner dim.	Side		PG	Corner dim.	Side	
		A/B	C/D			A/B	C/D
12	17,25	15	4	7	17,25	14	4
16	25,30	7	2	9	21,85	8	2
20	27,60	6	2	11	25,30	7	2
25	37,95			13,5	27,60	6	2
32	48,30			16	31,05	5	1
40	60,95			21	37,95		
50	69,00			29	48,30		
63	74,75			36	60,95		
				42	69,00		
				48	74,75		

* Please quote mounting side

Type: **04.12 12 08**

External dimensions: **120 x 120 x 81 mm**

Weight: **880 g**

DIN rail length in mm	max. fitting length in mm	Mounting plate (thickness in mm)	External mounting brackets	External hinge* set	EMC version	SWB / SBGL corrosion protection	Allen lid screws	Silicone lid seal	Sealable lid screws in steel	Lid safety strip
TS 15/TS 35										
107	90	2	•	•	•	•	•	•	•	•

Maximum number of cable glands to DIN 50262*

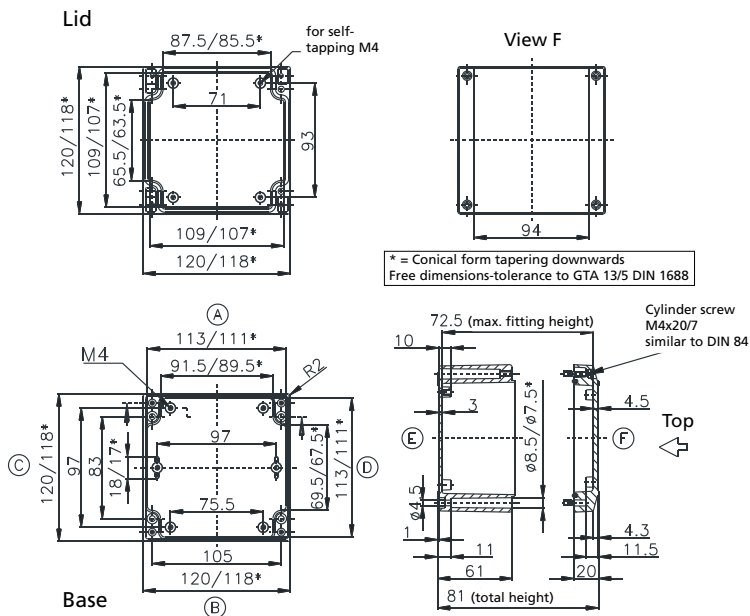

M	Corner dim.	Side		PG	Corner dim.	Side	
		A/B	C/D			A/B	C/D
12	17,25	15	11	7	17,25	15	11
16	25,30	6	6	9	21,85	8	6
20	27,60	5	4	11	25,30	6	5
25	37,95	2	2	13,5	27,60	5	4
32	48,30	2	1	16	31,05	3	2
40	60,95			21	37,95	2	2
50	69,00			29	48,30	2	1
63	74,75			36	60,95		
				42	69,00		
				48	74,75		

Type: **04.12 16 08**

External dimensions: **120 x 160 x 81 mm**

Weight: **830 g**

DIN rail length in mm	max. fitting length in mm	Mounting plate (thickness in mm)	External mounting brackets	External hinge* set	EMC version	SWB / SBGL corrosion protection	Allen lid screws	Silicone lid seal	Sealable lid screws in steel	Lid safety strip
TS 15/TS 35										
148	130	2	•	•	•	•	•	•	•	•

Maximum number of cable glands to DIN 50262*

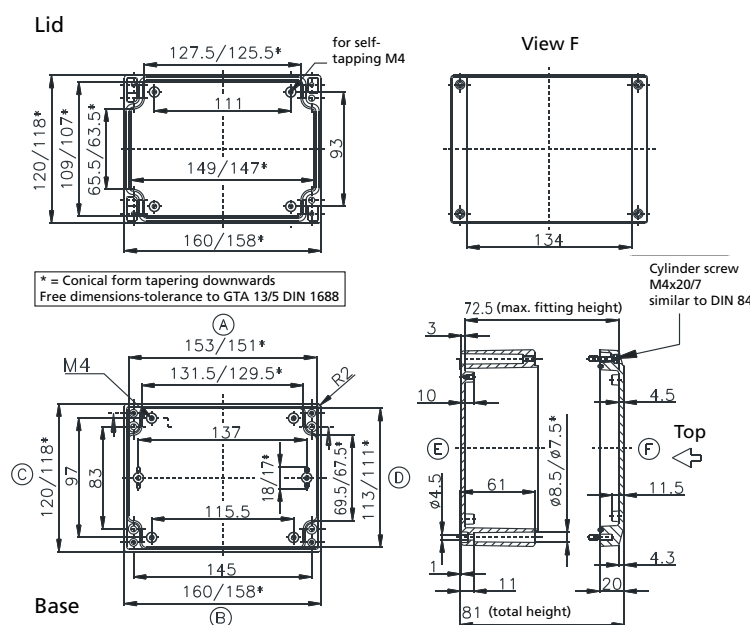

M	Corner dim.	Side		PG	Corner dim.	Side	
		A/B	C/D			A/B	C/D
12	17,25	21	11	7	17,25	21	11
16	25,30	10	6	9	21,85	12	6
20	27,60	8	4	11	25,30	10	5
25	37,95	4	2	13,5	27,60	8	4
32	48,30	3	1	16	31,05	5	2
40	60,95			21	37,95	3	2
50	69,00			29	48,30	2	1
63	74,75			36	60,95		
				42	69,00		
				48	74,75		

* Please quote mounting side

Type: **04.14 14 07**

External dimensions: **140 x 140 x 71 mm**

Weight: **800 g**

DIN rail length in mm	max. fitting length in mm	Mounting plate (thickness in mm)	External mounting brackets	External hinge* set	EMC version	SWB / SBGL corrosion protection	Allen lid screws	Silicone lid seal	Sealable lid screws in steel	Lid safety strip
TS 15/TS 35										
126	110	2	•	•	•	•	•	•	•	•

Maximum number of cable glands to **DIN 50262***

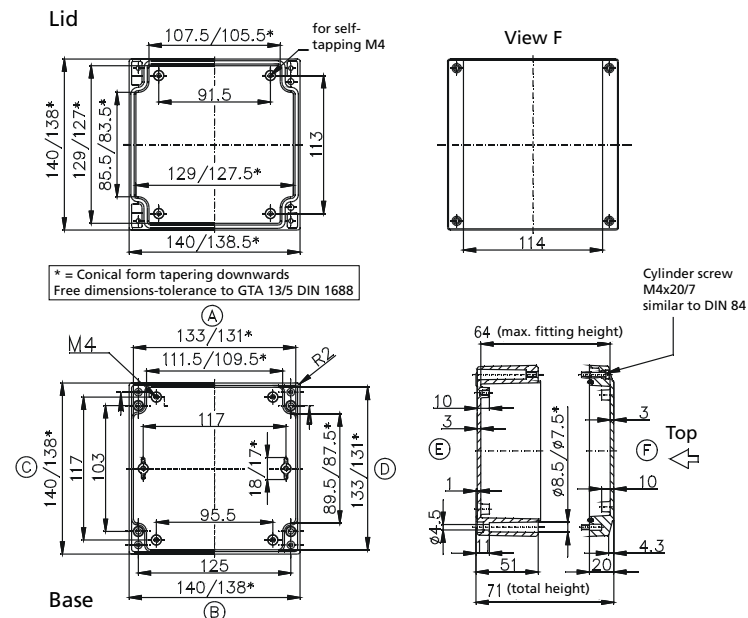

M	Corner dim.	Side		PG	Corner dim.	Side	
		A/B	C/D			A/B	C/D
12	17,25	12	10	7	17,25	12	10
16	25,30	5	4	9	21,85	9	7
20	27,60	4	3	11	25,30	5	4
25	37,95	3	2	13,5	27,60	4	3
32	48,30			16	31,05	3	3
40	60,95			21	37,95	3	2
50	69,00			29	48,30		
63	74,75			36	60,95		
				42	69,00		
				48	74,75		

Type: **04.14 18 07**

External dimensions: **140 x 180 x 71 mm**

Weight: **1000 g**

DIN rail length in mm	max. fitting length in mm	Mounting plate (thickness in mm)	External mounting brackets	External hinge* set	EMC version	SWB / SBGL corrosion protection	Allen lid screws	Silicone lid seal	Sealable lid screws in steel	Lid safety strip
TS 15/TS 35										
163	150	2	•	•	•	•	•	•	•	•

Maximum number of cable glands to **DIN 50262***

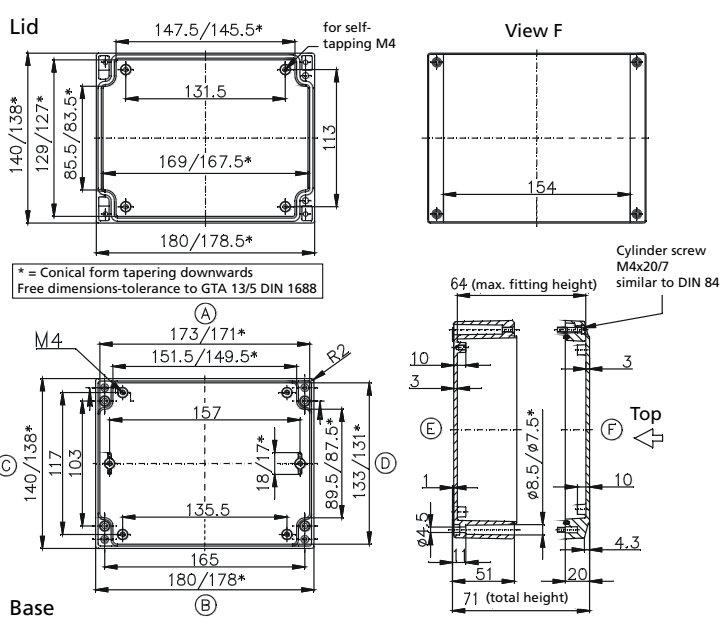

M	Corner dim.	Side		PG	Corner dim.	Side	
		A/B	C/D			A/B	C/D
12	17,25	17	10	7	17,25	17	10
16	25,30	8	4	9	21,85	13	7
20	27,60	6	3	11	25,30	7	4
25	37,95	4	2	13,5	27,60	6	3
32	48,30			16	31,05	5	3
40	60,95			21	37,95	4	2
50	69,00			29	48,30		
63	74,75			36	60,95		
				42	69,00		
				48	74,75		

* Please quote mounting side

Type: **04.14 22 07**

External dimensions: **140 x 220 x 72 mm**

Weight: **1266 g**

DIN rail length in mm	max. fitting length in mm	Mounting plate (thickness in mm)	External mounting brackets	External hinge* set	EMC version	SWB / SBG / SBGL corrosion protection	Allen lid screws	Silicone lid seal	Sealable lid screws in steel	Lid safety strip
TS 15/TS 35										
206	190	2	•	•	•	•	•	•	•	•

Maximum number of cable glands to DIN 50262*

M	Corner dim.	Side		PG	Corner dim.	Side	
		A/B	C/D			A/B	C/D
12	17,25	22	10	7	17,25	22	10
16	25,30	10	4	9	21,85	16	7
20	27,60	8	3	11	25,30	9	4
25	37,95	5	2	13,5	27,60	8	3
32	48,30			16	31,05	6	3
40	60,95			21	37,95	5	2
50	69,00			29	48,30		
63	74,75			36	60,95		
				42	69,00		
				48	74,75		

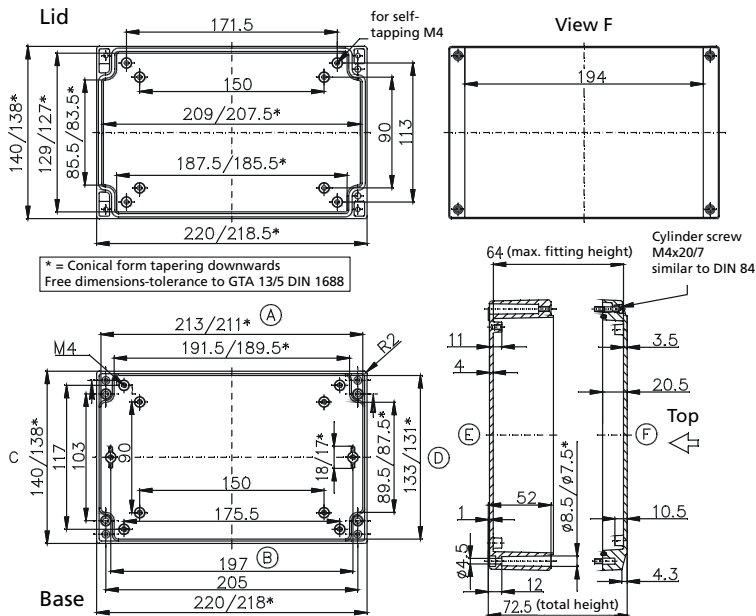

Type: **04.15 18 08**

External dimensions: **150 x 180 x 81 mm**

Weight: **1100 g**

DIN rail length in mm	max. fitting length in mm	Mounting plate (thickness in mm)	External mounting brackets	External hinge* set	EMC version	SWB / SBG / SBGL corrosion protection	Allen lid screws	Silicone lid seal	Sealable lid screws in steel	Lid safety strip
TS 15										

Max. Bestückungsmöglichkeit für Kabelverschraubungen nach DIN 50262*

M	Corner dim.	Side		PG	Corner dim.	Side	
		A/B	C/D			A/B	C/D
12	17,25	24	15	7	17,25	24	15
16	25,30	12	8	9	21,85	14	9
20	27,60	10	6	11	25,30	12	8
25	37,95	4	3	13,5	27,60	10	6
32	48,30	3	2	16	31,05	7	4
40	60,95			21	37,95	4	3
50	69,00			29	48,30	3	2
63	74,75			36	60,95		
				42	69,00		
				48	74,75		

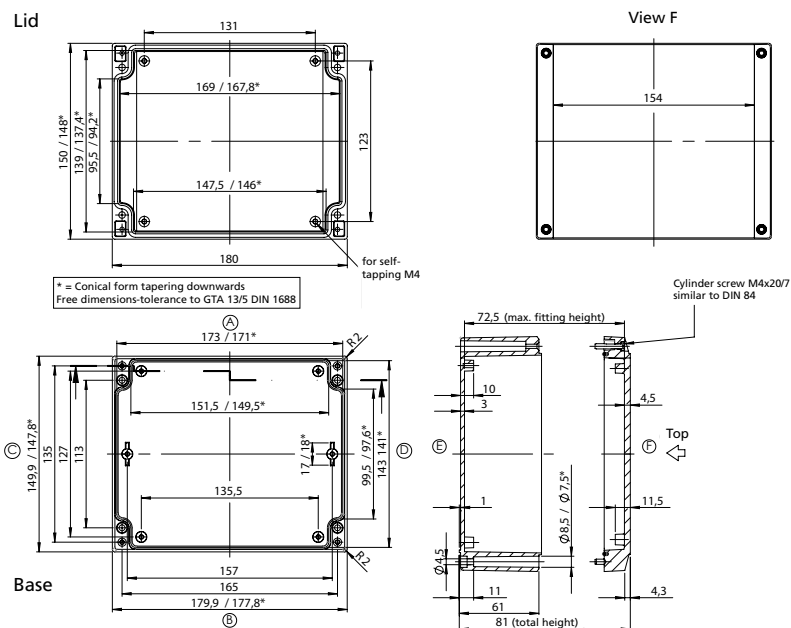

* Please quote mounting side

Type: **04.16 16 08**

External dimensions: **160 x 160 x 81 mm**

Weight: **1120 g**

DIN rail length in mm	max. fitting length in mm	Mounting plate (thickness in mm)	External mounting brackets	External hinge* set	EMC version	SWB / SBG / SBGL corrosion protection	Allen lid screws	Silicone lid seal	Sealable lid screws in steel	Lid safety strip
TS 15/TS 35										
148	130	2	•	•	•	•	•	•	•	•

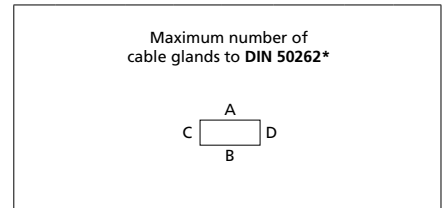

M	Corner dim.	Side		PG	Corner dim.	Side	
		A/B	C/D			A/B	C/D
12	17,25	21	18	7	17,25	21	18
16	25,30	10	8	9	21,85	12	10
20	27,60	8	7	11	25,30	10	8
25	37,95	4	3	13,5	27,60	8	7
32	48,30	3	2	16	31,05	5	4
40	60,95			21	37,95	3	3
50	69,00			29	48,30	2	2
63	74,75			36	60,95		
				42	69,00		
				48	74,75		

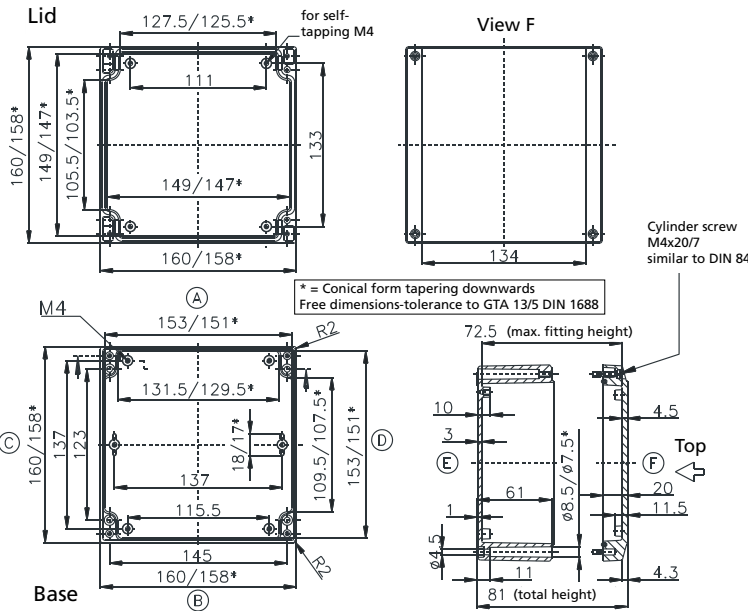

Type: **04.16 24 08**

External dimensions: **160 x 240 x 81 mm**

Weight: **1900 g**

DIN rail length in mm	max. fitting length in mm	Mounting plate (thickness in mm)	External mounting brackets	External hinge* set	EMC version	SWB / SBG / SBGL corrosion protection	Allen lid screws	Silicone lid seal	Sealable lid screws in steel	Lid safety strip
TS 15/TS 35										
228	210	2	•	•	•	•	•	•	•	•

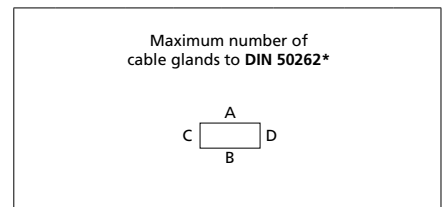

M	Corner dim.	Side		PG	Corner dim.	Side	
		A/B	C/D			A/B	C/D
12	17,25	36	18	7	17,25	36	18
16	25,30	16	8	9	21,85	18	10
20	27,60	14	7	11	25,30	16	8
25	37,95	6	3	13,5	27,60	14	7
32	48,30	4	2	16	31,05	9	4
40	60,95			21	37,95	6	3
50	69,00			29	48,30	4	2
63	74,75			36	60,95		
				42	69,00		
				48	74,75		

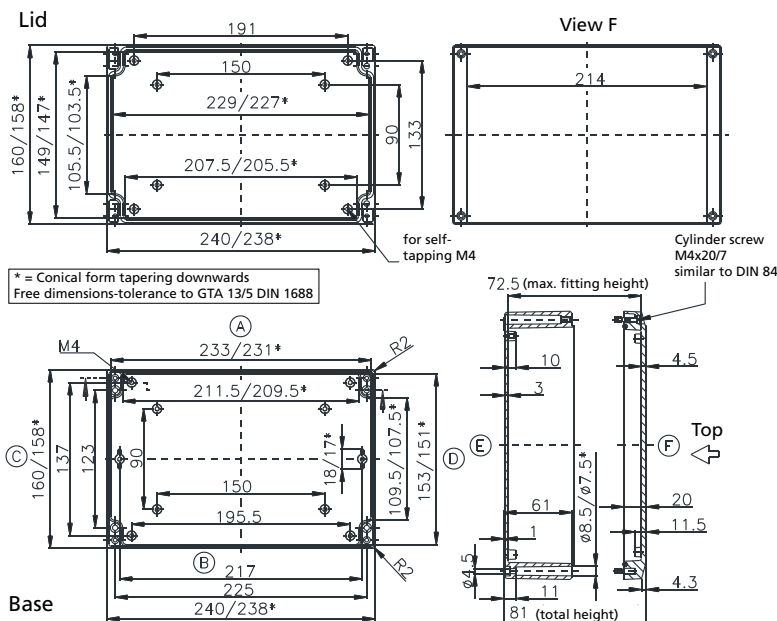

* Please quote mounting side

Type: **04.20 20 07**

External dimensions: **200 x 200 x 72 mm**

Weight: **1440 g**

DIN rail length in mm	max. fitting length in mm	Mounting plate (thickness in mm)	External mounting brackets	External hinge* set	EMC version	SWB / SBG / SBGL corrosion protection	Allen lid screws	Silicone lid seal	Sealable lid screws in steel	Lid safety strip
TS 15/TS 35										
188	170	2	•	•	•	•	•	•	•	•

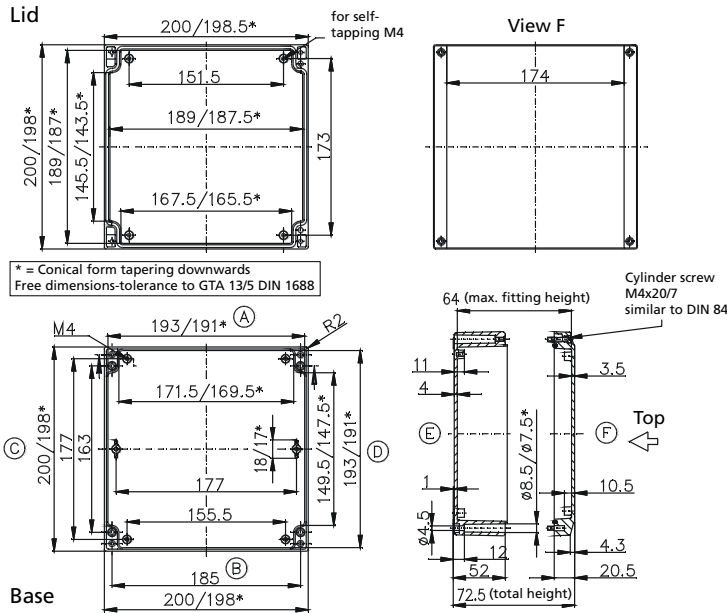
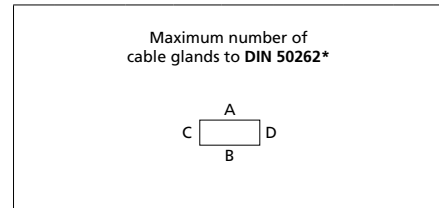

M	Corner dim.	Side		PG	Corner dim.	Side	
		A/B	C/D			A/B	C/D
12	17,25	20	17	7	17,25	20	17
16	25,30	9	8	9	21,85	14	13
20	27,60	7	6	11	25,30	8	7
25	37,95	4	4	13,5	27,60	7	6
32	48,30			16	31,05	6	5
40	60,95			21	37,95	4	4
50	69,00			29	48,30		
63	74,75			36	60,95		
				42	69,00		
				48	74,75		

Type: **04.20 28 07**

External dimensions: **200 x 280 x 72 mm**

Weight: **1920 g**

DIN rail length in mm	max. fitting length in mm	Mounting plate (thickness in mm)	External mounting brackets	External hinge* set	EMC version	SWB / SBG / SBGL corrosion protection	Allen lid screws	Silicone lid seal	Sealable lid screws in steel	Lid safety strip
TS 15/TS 35										
266	250	2	•	•	•	•	•	•	•	•

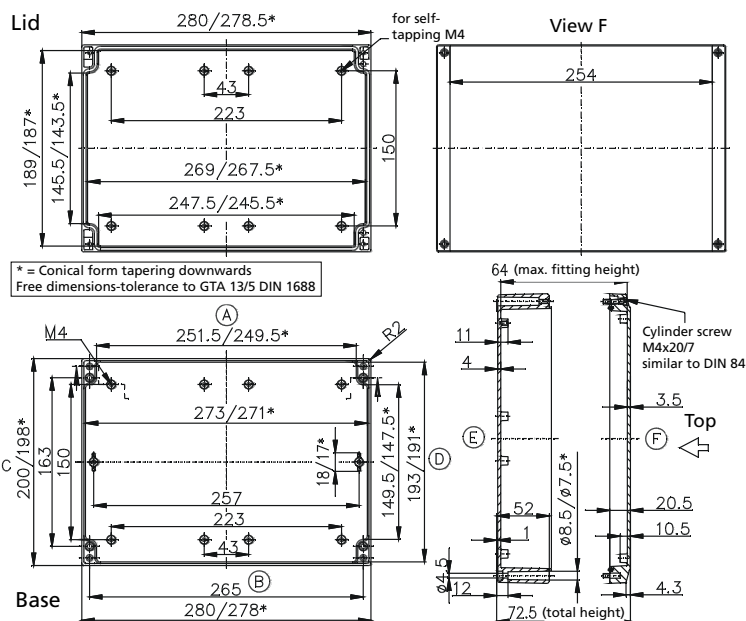
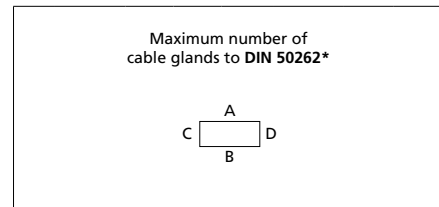

M	Corner dim.	Side		PG	Corner dim.	Side	
		A/B	C/D			A/B	C/D
12	17,25	29	17	7	17,25	29	17
16	25,30	13	8	9	21,85	22	13
20	27,60	10	6	11	25,30	12	7
25	37,95	6	4	13,5	27,60	10	6
32	48,30			16	31,05	8	6
40	60,95			21	37,95	6	4
50	69,00			29	48,30		
63	74,75			36	60,95		
				42	69,00		
				48	74,75		

* Please quote mounting side

DIN rail length in mm	max. fitting length in mm	Mounting plate (thickness in mm)	External mounting brackets	External hinge* set	EMC version	SWB / SBG / SBGL corrosion protection	Allen lid screws	Silicone lid seal	Sealable lid screws in steel	Lid safety strip
			•	•	•	•	•	•	•	•

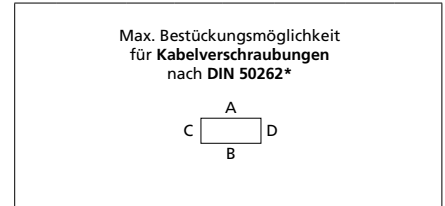

Lid

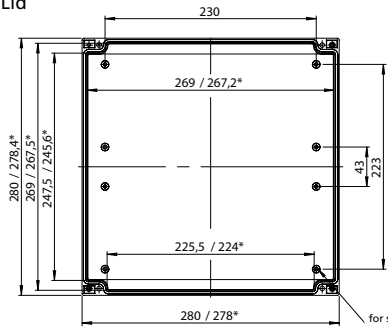

View F

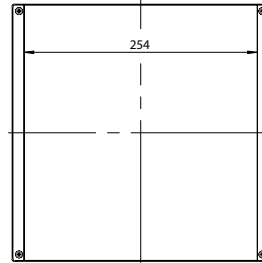

* - Conical form tapering downwards
Free dimensions-tolerance to GTA 13/5 DIN 1688

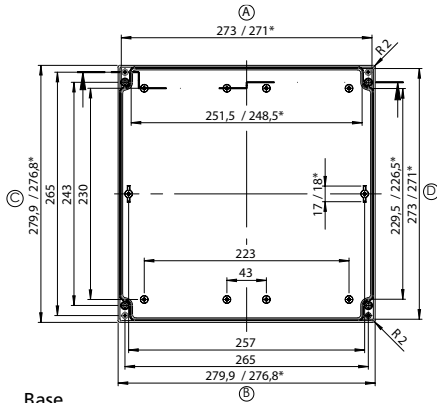

Base

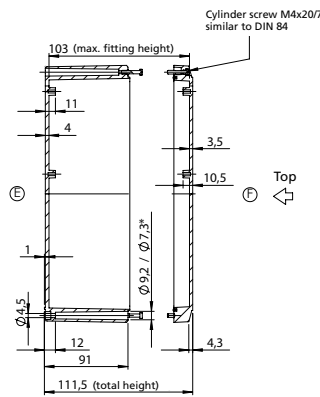

M	Corner dim.	Side		PG	Corner dim.	Side	
		A/B	C/D			A/B	C/D
12	17,25	70	65	7	17,25	70	65
16	25,30	30	27	9	21,85	44	40
20	27,60	27	24	11	25,30	30	27
25	37,95	12	12	13,5	27,60	27	24
32	48,30	8	7	16	31,05	21	20
40	60,95	4	4	21	37,95	12	12
50	69,00	4	3	29	48,30	7	6
63	74,75	3	3	36	60,95	4	4
				42	69,00	3	3
				48	74,75	3	3

* Please quote mounting side