



- Plastic enclosure with flange openings for automation technology
- Combination options with other polyester flange enclosures
- Snap lock technology

Technical data

Material:

glass fibre reinforced duroplastic polyester
transparent lid: polycarbonate

Colour:

RAL 7032, pebble grey

Ingress protection:

IP 65 to EN 60529

Impact resistance:

7 Joule to EN 60079-0

Flammability:

enclosure: V0 / self-extinguishing, UL 94
transparent lid: V2 / UL 94

Insulation:

fully insulated VDE 0100

Disruptive strength:

enclosure: 24KV/mm / IEC 60243-1
transparent lid: >30 KV/mm / IEC 60243-1

Toxicity:

halogen-free

Surface resistance:

enclosure: >10¹¹ Ohm / IEC 60093
transparent lid: >10¹⁵ Ohm / IEC 60093

Temperature range:

PU (polyurethane) seal:
-40°C to +90°C (enclosure)
-40°C to +100°C (lid)
CR (chloroprene) seal: -40°C to +100°C
VMQ (silicone) seal: -60°C to +130°C

Included in delivery

Plastic enclosure in glass fibre reinforced polyester, consisting of lid, seal, plastic quick-release fastener screws, base with flange openings.

(Please order flange plate separately)
Threaded insert set (4 pcs.)

Polyester Flange

Product range

Order No.	W x L x H (mm)	Flange openings	Mounting plate	Front plate on stud bolt	DIN rail* TS 35	Earth rail	Silicone lid seal 130°
14.01 00 00	170 x 270 x 136	2	14.00 00 11	14.00 00 27	10.06 17 21	10.06 21 01	10.05 15 01
14.02 00 00	270 x 270 x 136	4	14.00 00 12	14.00 00 28	10.06 17 22	10.06 21 01	10.05 15 02
14.03 00 00	270 x 541 x 136	6	14.00 00 13	14.00 00 29	10.06 17 23	10.06 21 02	10.05 15 03
Version with polycarbonate transparent lid							
14.01 00 01	170 x 270 x 150	2	14.00 00 11	14.00 00 27	10.06 17 21	10.06 21 01	10.05 15 01
14.02 00 01	270 x 270 x 150	4	14.00 00 12	14.00 00 28	10.06 17 22	10.06 21 01	10.05 15 02
14.03 00 01	270 x 540 x 150	6	14.00 00 13	14.00 00 29	10.06 17 23	10.06 21 02	10.05 15 03

* TS 32 on request

Flange and accessories (for all types)

Blind flange (for individual machining)	14.00 00 20	Lid hinges (2 pcs.) retrofitting for all types	14.00 00 26
Threaded flange (17 x PG 11)	14.00 00 30	External mounting brackets (4 pcs.)	10.03 11 02
Threaded flange (14 x PG 13,5)	14.00 00 22	Threaded inserts (10 pcs.) additional	10.03 50 02
Threaded flange (11 x PG 16)	14.00 00 21	Silicone seal for flanges	10.05 14 02
Threaded flange (4 x PG 16; 2 x PG 21; 1 x PG 29)	14.00 00 23	Silicone seal for connection flange	10.05 14 03
Connection flange	14.00 00 25		

Terminal mounting

Make	Phoenix														Earthing bar 2.5 mm ² with cable lug max. 10 mm ²	Earthing screw M4 with cable lug max. 6 mm ²	M6 with cable lug max. 35 mm ²	Earth connections as required
DIN rail TS 15	X	X	X															
DIN rail TS 35				X	X	X	X	X	X	X	X	X	X	X				
Voltage (V)	250	500	500	500	800	800	800	800	800	800	1000	1000	1000	1000				
Current (A)	24	24	32	17,5	24	24	32	41	57	76	125	150	232	309	415			
Nom. cross section (mm ²)	2,5	2,5	4	1,5	2,5	2,5	4	6	10	16	35	50	95	150	240			
Terminal width (mm)	5,2	5,2	6,2	4,2	5,2	5,2	6,2	8,2	10,2	12,2	16	20	25	31	36			
Terminal type																		
Type	MBK 2,5 E	MBK 3 / E-Z	MBK 5 / E-Z	UK 1,5 N	UK 2,5 N	UK 3 N	UK 5 N	UK 6 N	UK 10 N	UK 16 N	UK 35	UKH 50	UKH 95	UKH 150	UKH 240			
14.01 00 . .	44	44	37	54	44	44	37	28	22	18	15					20		
14.02 00 . .	88	88	74	108	88	88	74	56	44	36	30					20		
14.03 00 . .	192	192	160	238	192	192	160	122	98	82	64	50				40		

Make	Weidmüller													
DIN rail TS 15	X	X	X	X	X									
DIN rail TS 35					X	X	X	X	X	X	X	X		
Voltage (V)	250	400	250	400	500	800	800	800	1000	1000	1000	1000		
Current (A)	17,5	17,5	24	32	24	24	32	41	57	76	125	150		
Nom. cross section (mm ²)	1,5	1,5	2,5	4	2,5	2,5	4	6	10	16	35	50		
Terminal width (mm)	5,1	3,5	5,1	6,1	5,1	5,1	6,1	7,9	9,9	11,9	16	18,5		
Terminal type														
Type	AKZ 1,5	WDU 1,5 / R 3,5	AKZ 2,5	AKZ 4	WDU 2,5 N	WDU 2,5	WDU 4	WDU 6	WDU 10	WDU 16	WDU 35	WDU 50 N		
14.01 00 . .	42	58	41	35	44	44	37	28	22	18				
14.02 00 . .	68	98	68	56	76	76	64	48	38	16	12			
14.03 00 . .	174	250	174	144	184	184	154	116	92	38	29	48		

Earthing bar and earth connection see terminal mounting Phoenix

Accessories



Blind flange
weight: 225 g

Order No.	Version
14.00 00 20	without holes



Threaded flange
with pre-embossed PG holes
with metric pre-embossing on request

Order No.	Version
14.00 00 30	17 x PG 11
14.00 00 22	14 x PG 13,5
14.00 00 21	11 x PG 16
14.00 00 23	4 x PG 16; 2 x PG 21; 1 x PG 29



Connection flange
to connect two polyester flange enclosures

Order No. **14.00 00 25**



Lid hinges
set = 2 pcs., retrofittable to all polyester flange enclosures

Order No. **14.00 00 26**

Polyester Flange

Accessories



External mounting brackets
set = 4 pcs.

Order No. **10.03 11 02**

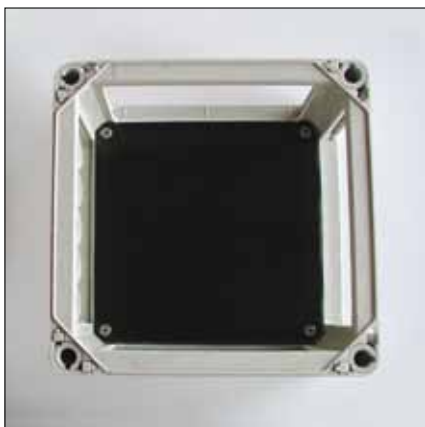
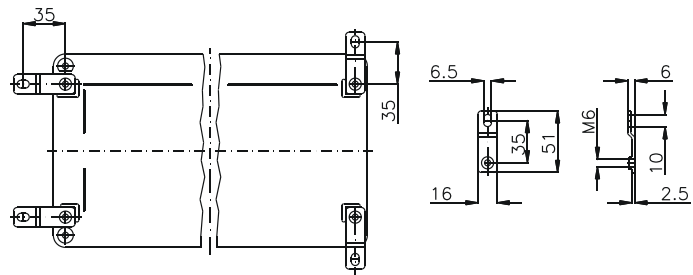

Mounting plates
for fitting electro-mechanical components

Order-No.	Type
14.00 00 11	14.01
14.00 00 12	14.02
14.00 00 13	14.03



Front plate
with stud bolts and fastening screws
(for dimensions, refer to mounting plate)

Order-No.	Type
14.00 00 27	14.01
14.00 00 28	14.02
14.00 00 29	14.03

Type: **14.01 . .**

External dimensions: **170 x 270 x 136 mm**

Weight: **2140 g**

DIN rail length in mm	max. fitting length in mm	Mounting plate (thickness in mm)	External mounting bracket	Lid hinges	No. of flanges			
TS 15/35								
255	240	3	•	•	2			

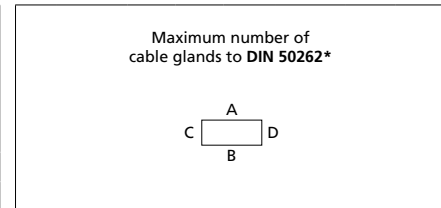

M	Corner dim.	Side		PG	Corner dim.	Side	
		A/B	C/D			A/B	C/D
12	17,25	63	33	7	17,25	63	33
16	25,30	28	16	9	21,85	38	20
20	27,60	22	12	11	25,30	28	14
25	37,95	12	6	13,5	27,60	22	12
32	48,30	8	4	16	31,05	18	9
40	60,95	3	2	21	37,95	11	6
50	69,00	3	1	29	48,30	8	4
63	74,75	2	1	36	60,95	3	2
				42	69,00	3	1
				48	74,75	2	1

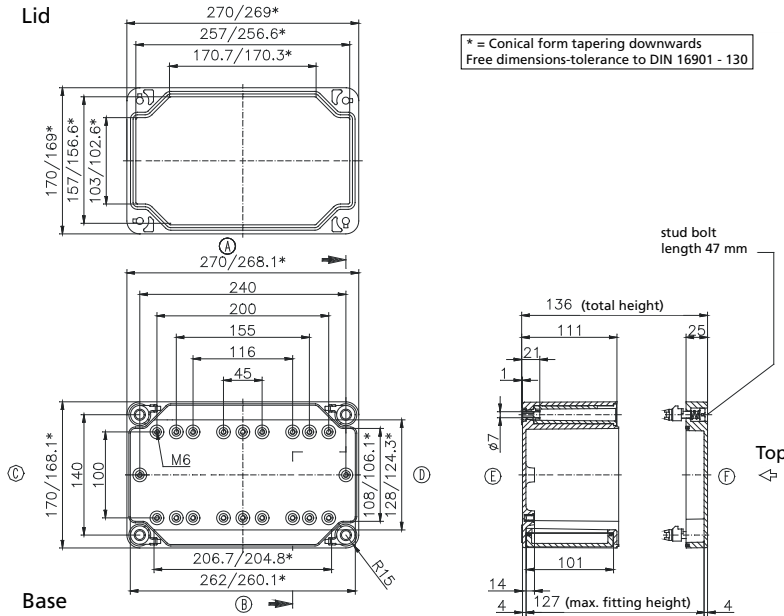

Type: **14.02 . .**

External dimensions: **270 x 270 x 136 mm**

Weight: **2750 g**

DIN rail length in mm	max. fitting length in mm	Mounting plate (thickness in mm)	External mounting bracket	Lid hinges	No. of flanges			
TS 15/35								
215	200	3	•	•	4			

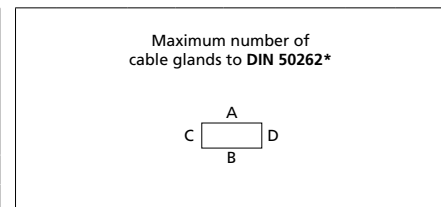

M	Corner dim.	Side		PG	Corner dim.	Side	
		A/B	C/D			A/B	C/D
12	17,25	63	63	7	17,25	63	63
16	25,30	28	28	9	21,85	38	38
20	27,60	22	22	11	25,30	28	28
25	37,95	12	12	13,5	27,60	22	22
32	48,30	8	8	16	31,05	18	18
40	60,95	3	3	21	37,95	11	11
50	69,00	3	3	29	48,30	8	8
63	74,75	2	2	36	60,95	3	3
				42	69,00	3	3
				48	74,75	2	2

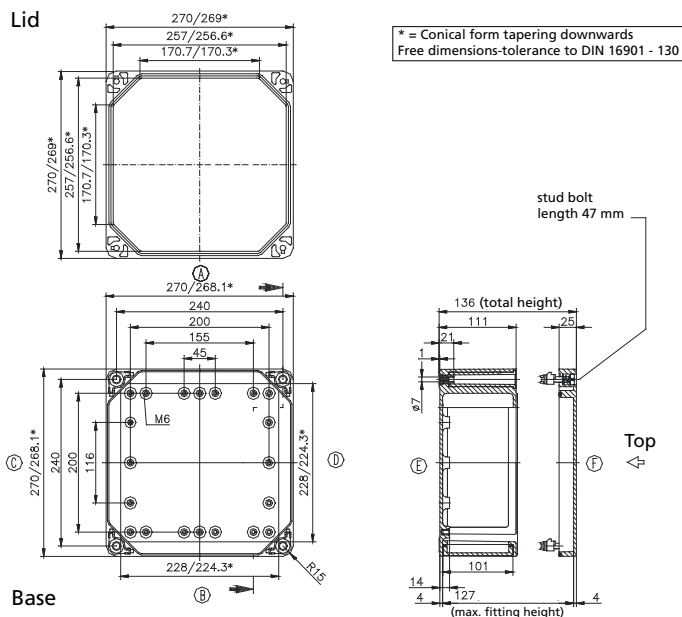

Type: **14.03 . .**

External dimensions: **270 x 541 x 136 mm**

Weight: **4800 g**

DIN rail length in mm	max fitting length in mm	Mounting plate (thickness in mm)	External mounting bracket	Lid hinges	No. of flanges			
TS 15/35								
485	470	3	•	•	6			

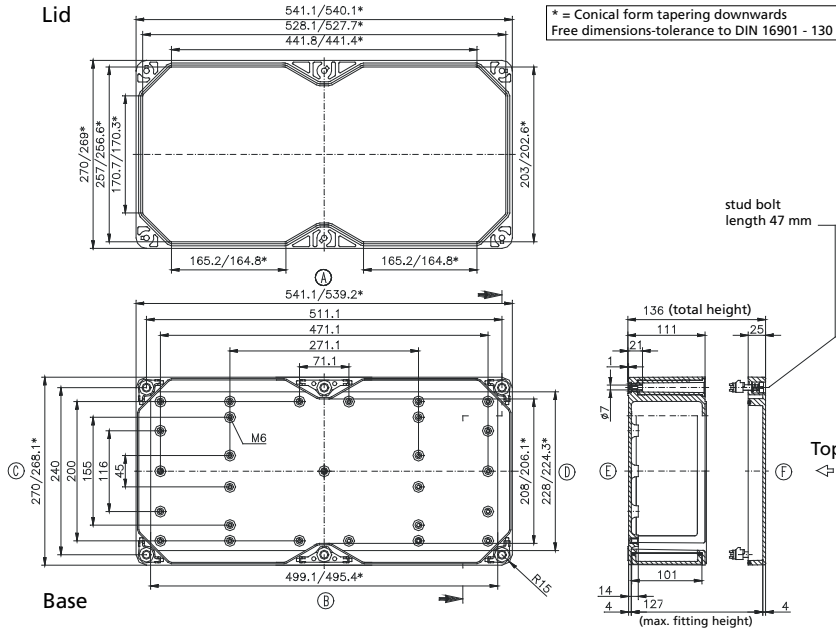
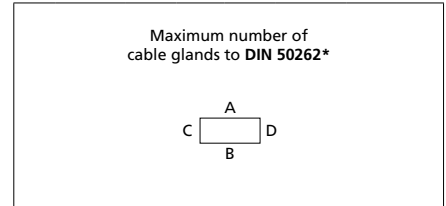

M	Corner dim.	Side		PG	Corner dim.	Side	
		A/B	C/D			A/B	C/D
12	17,25	63	63	7	17,25	63	63
16	25,30	28	28	9	21,85	38	38
20	27,60	22	22	11	25,30	28	28
25	37,95	12	12	13,5	27,60	22	22
32	48,30	8	8	16	31,05	18	18
40	60,95	3	3	21	37,95	11	11
50	69,00	3	3	29	48,30	8	8
63	74,75	2	2	36	60,95	3	3
				42	69,00	3	3
				48	74,75	2	2

* per flange